

The remarkably simple solution that provides easy interchangeability, upgradeability and replacement

The Helieon lighting system is the first plug-and-play, sustainable solid state lighting module to integrate high-efficiency precision lighting with an easy-to-use socketed solution to accelerate innovation and enable the mass adoption of solid state lighting. Combining unmatched solid state lighting technology from Bridgelux and interconnect technology from Molex, the Helieon lighting system simplifies the process of designing, building, replacing and upgrading luminaires.

Helieon modules enable flexibility in changing the look and feel of the lighting installation with the simplicity of replacing a light bulb. By emulating a traditional lighting socket, the Helieon system delivers an easy and familiar installation experience. Beam angle, color temperature and light output can all be easily changed or upgraded with the simple twist of a wrist after installation — without the complexity and expense of removing the luminaire.

Product options are tailored to match light output levels of traditional light sources, delivering between 500 and 1,500 lumens under application conditions in halogen and fluorescent color temperature options. Helieon modules are available with narrow, medium and wide flood beam spread options that enable precision effects for a wide variety of lighting applications.

Helieon™ Sustainable Light Module



Helieon Module

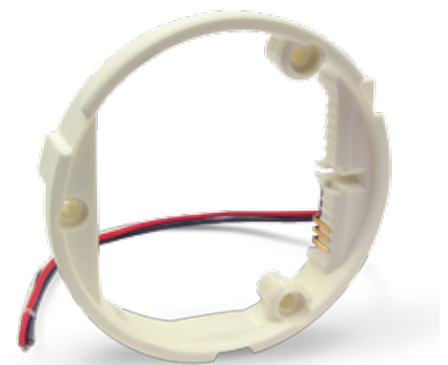

Helieon Socket

FEATURES

- Integrated solid state lighting solution for OEM fixture manufacturers, lighting designers and architects
- Multiple product options compatible with a single thermal and electronic driver system design
- Separable socketed plug-and-play solution (socket and module) with a turn-and-click installation process
- Uniform high-quality illumination with beam control optics (24, 32 and 50 degree options)
- High system efficacy enables luminaires with operating efficiencies of >50 lm/W
- Color controlled to a single 3-step MacAdams ellipse
- UL recognized (pending)
- Three year limited warranty
- Recyclable components, Pb and Mercury free, RoHS compliant

BENEFITS

- Simplifies the design integration effort and accelerates time to market
- Enables flexibility to change the lighting experience after installation
- Enables separation of source and fixture, emulating traditional lighting with a familiar turn-and-click installation process
- Delivers clean white light without pixilation for precision lighting effects
- Meets or exceeds global regulatory requirements such as Energy Star, Title 24, Part L and others
- Uniform consistent white light between luminaires in the lighting installation
- Streamlines the UL-listing process for the luminaire
- Enables luminaire manufacturers to design with confidence
- Reduces environmental and disposal issues, delivering a sustainable solution

APPLICATIONS

- Down lights
- Task and accent lighting
- Spot and track lights
- Troffers and interior-area lighting
- Retail and display lighting
- Hospitality lighting
- Architectural lighting
- Decorative lighting
- Museum lighting



TYPICAL PRODUCT PERFORMANCE

Helieon™ Sustainable Light Module

800 Lumen Series

Part Number ⁽¹⁾	CCT	CRI	Beam Angle (FWHM)	Forward Current (mA)	Hot Lumens (T _c 60°C) ⁽²⁾	Voltage (T _c 60°C) (V) ⁽³⁾	Nominal Wattage (T _c 60°C) (W)	Nominal Efficacy (T _c 60°C) (lm/W)
180081-22x0	3000K	82	24°, 32° and 50°	700	490	11.4	7.9	62
				1050	710	11.9	12.4	57
				1400	860	12.3	17.2	50
180081-42x0	4100K	80	24°, 32° and 50°	700	550	11.4	7.9	70
				1050	800	11.9	12.4	64
				1400	1020	12.3	17.2	59

1200 Lumen Series

Part Number ⁽¹⁾	CCT	CRI	Beam Angle (FWHM)	Forward Current (mA)	Hot Lumens (T _c 60°C) ⁽²⁾	Voltage (T _c 60°C) (V) ⁽³⁾	Nominal Wattage (T _c 60°C) (W)	Nominal Efficacy (T _c 60°C) (lm/W)
180081-23x0	3000K	82	24°, 32° and 50°	700	730	17.2	12.0	61
				1050	1040	17.9	18.8	56
				1400	1330	18.5	25.8	51
180081-43x0	4100K	80	24°, 32° and 50°	700	840	17.2	12.0	70
				1050	1200	17.9	18.8	64
				1400	1530	18.5	25.8	59

The Helieon Sustainable Light Module is available in 24° narrow flood, 32° medium flood and 50° wide flood viewing angle options. See Note 1 below for part number designation for beam angle options.

NOTES:

1. x = beam angle (2=24°, 3=32°, 5=50°)

2. Lumen range is within ±10% of the nominal value

3. Voltage range is within ±10% of the nominal value

Helieon Socket / Part Number: 180080-0000

MAXIMUM PRODUCT RATINGS

Parameter	Maximum Rating
Maximum DC Forward Current	2000mA
Minimum DC Forward Current ⁽¹⁾	600mA
Maximum Peak Pulsed Current ⁽²⁾	2800mA
Maximum Reverse Voltage ⁽³⁾	-20V
Operating Temperature	-40°C to +95°C
Storage Temperature	-40°C to +105°C

NOTES:

1. Driving these high-current devices at low currents can result in variations in performance. For low-current operation, pulse width modulation is recommended.

2. A maximum duty cycle of 10% is recommended when operating the Helieon module at the maximum peak pulsed current specified.

3. LEDs are not designed to be driven with a reverse voltage.

MECHANICAL SPECIFICATIONS

Helieon Module

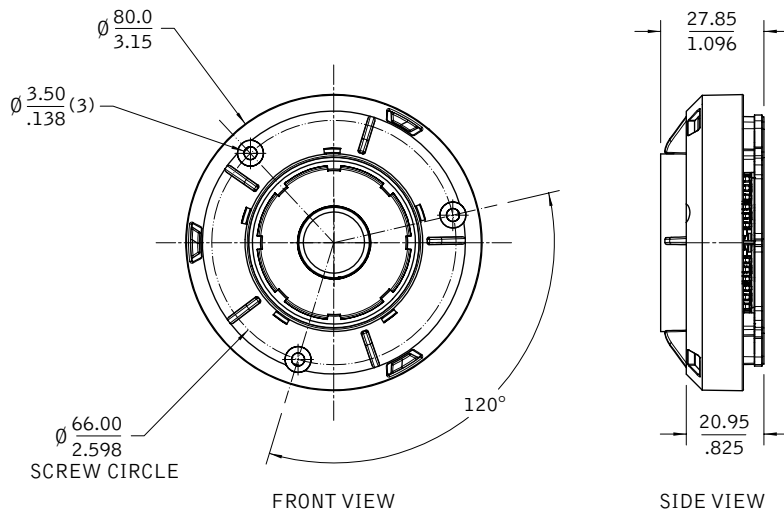

Helieon Socket

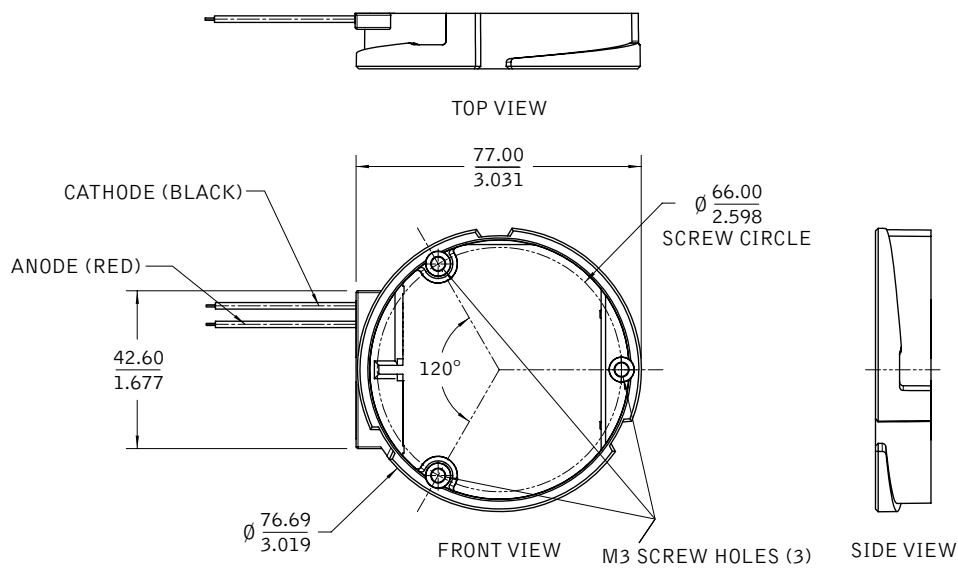

Mated Helieon System

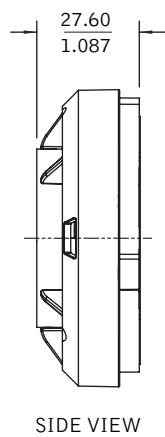

Average Lumen Maintenance Characteristics

The Helieon Sustainable Light Module is projected to deliver, on average, greater than 70% lumen maintenance after 50,000 hours of operation at the rated forward-test current. This performance assumes constant current operation with the module case temperature (T_c) maintained at or below 60°C. For use beyond these typical conditions, please consult your Helieon system sales representative for further assistance.

Environmental Compliance

Molex and Bridgelux are committed to providing environmentally friendly products to the solid state lighting market. The Helieon system is compliant to the European Union directives on the restriction of hazardous substances in electronic equipment, namely the RoHS directive. The following restricted materials will not be intentionally added to the Helieon system: lead, mercury, cadmium, hexavalent chromium, polybrominated biphenyls (PBB) or polybrominated diphenyl ethers (PBDE).

Minor Product Change Policy

The rigorous product qualification testing of the Helieon system provides performance assurance. Slight cosmetic changes that do not affect form, fit or function may occur as the Helieon system continues to be optimized.

PHOTOMETRICS (1050 mA Operating Current)

24-Degree Beam Angle

		3000K		4100K	
Distance (m)	Effective Diameter (m)	Helieon P/N 180081-2220	Helieon P/N 180081-2320	Helieon P/N 180081-4220	Helieon P/N 180081-4320
		Center Illuminance (lux)	Center Illuminance (lux)	Center Illuminance (lux)	Center Illuminance (lux)
1	0.43	1240	1580	1460	2000
2	0.85	310	400	370	500
3	1.28	140	180	160	220
4	1.70	80	100	90	130

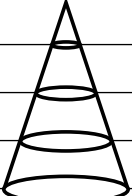

32-Degree Beam Angle

		3000K		4100K	
Distance (m)	Effective Diameter (m)	Helieon P/N 180081-2230	Helieon P/N 180081-2330	Helieon P/N 180081-4230	Helieon P/N 180081-4330
		Center Illuminance (lux)	Center Illuminance (lux)	Center Illuminance (lux)	Center Illuminance (lux)
1	0.63	1090	1420	1320	1890
2	1.26	270	350	330	470
3	1.89	120	160	150	210
4	2.52	70	90	80	120

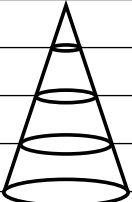

50-Degree Beam Angle

		3000K		4100K	
Distance (m)	Effective Diameter (m)	Helieon P/N 180081-2250	Helieon P/N 180081-2350	Helieon P/N 180081-4250	Helieon P/N 180081-4350
		Center Illuminance (lux)	Center Illuminance (lux)	Center Illuminance (lux)	Center Illuminance (lux)
1	0.93	670	880	750	1140
2	1.87	170	220	190	290
3	2.80	70	100	80	130
4	3.73	40	60	50	70

