



eLucent™

GX1019 XPower LED Lamps

"The government says that if every American home replaced one light bulb with a compact fluorescent light bulb, we could save enough energy to prevent greenhouse gases equal to the emissions of more than 800,000 cars. Certainly great news, yet recycling burned-out CFL light bulbs poses a quandary for homeowners."

The Dallas Morning News, April 17, 2008

Leds Online Canada eLucent™ GX1019 XPower LED Lamps are compact, green and high efficiency lighting fixtures, ideal alternatives to conventional incandescent lamps and CFL lamps. They are well-suited for use in interior architectural, retail, exhibit and display lighting applications.

With patented thermal control technology, and special designed aluminum alloy housing substantially achieves good thermal property. With this unique design, eLucent™ GX1019 is of much more stable performance and of course will last for around 50,000 hours compared to 1,000 hours from incandescent lamps and 5,000 to 10,000 hours from CFLs.

eLucent™ GX1019 adopt powerful LED light source with standard MR16, GU10, E27 base, which can be easily dropped into the existing sockets.

eLucent™ GX1019 offer green and high efficiency illumination lighting solutions. They have many advantages against incandescent light bulbs such as energy-saving, pollution-free, long life span etc. With so many benefits, eLucent™ GX1019 are gradually replacing the conventional light bulbs for homes, offices, museums, galleries, shopwindows, casinos, bars, restaurants, hotels, malls, exhibitions, and meeting rooms etc.



Features & Benefits:

Good thermal property with special designed aluminum alloy housing;
High brightness with powerful LED light source to achieve the illumination purpose;
High shock and vibration resistant with aluminum body;
Low power consumption, save energy and maintenance cost;
Low heat generation, no heat damage to achieve ideal

display lighting;
Solid-state, fast turn on;
Easy installation with existing socket;
Low heat generation, no heat damage.

Recommended Applications:

Illumination lighting for homes, offices, restaurants, hotels, malls, casinos, bars etc;
Display lighting for museums, galleries, stores, malls, shopwindows, exhibitions etc.

eLucent™ GX1019 for Illumination Lighting

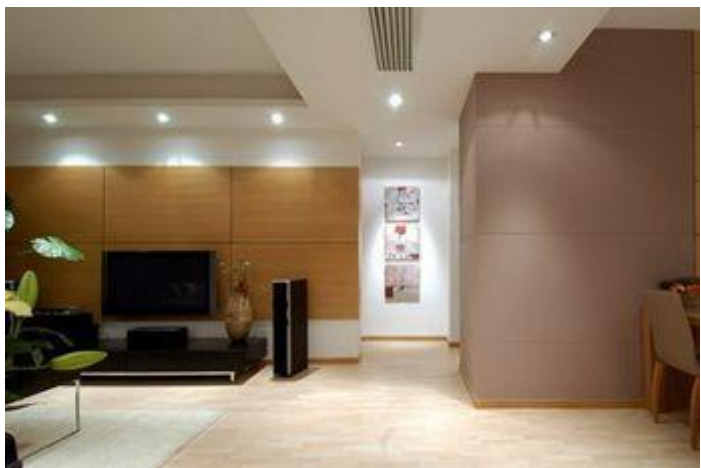



Lighting occupies as much as 10 to 15 percent of the energy in a typical residence. Much of this consumption is unnecessary because of the use of inefficient conventional lamps. But as a green lighting source, our eLucent™ GX1019 can help you to solve this situation. They substantially reduce this energy use but without sacrificing comfort and convenience. You can find the right places in your homes, offices, restaurants, hotels, malls, casinos, bars and meeting rooms for this green lighting fixture.



eLucent™ GX1019 for Display Lighting

eLucent™ GX1019 XPower LED Lamps are ideal replacement lamps for display lighting, especially in museums, galleries and other places where UV, IR or heat radiation is undesirable. You needn't be worried that your articles will suffer from light damages. Especially for the valuable articles such as jewelries and antiques etc, avoiding the light damages is of great importance.



What's more, eLucent™ GX1019 reduce glare and improves product visibility. Therefore you can not only achieve display purpose but also can avoid submerging your articles in the extreme glare light.

Just abandon your poor display lighting fixtures, and adopt eLucent™ GX1019 to easily draw your customer's attention to your merchandises on display in your museums, galleries, stores, malls, shopwindows, exhibitions etc.





Part Numbers

Part Number	Description	Unit
HGX-1032N-03115E-L1	GX1019, 3LEDsx1W, Natural white, MR16, 12VDC, 30 degree, Edison LED	pcs
HGX-2032N-03115E-H0	GX1019, 3LEDsx1W, Natural white, E27, 120VAC/240VAC, 30 degree, Edison LED	pcs
HGX-3032N-03115E-H0	GX1019, 3LEDsx1W, Natural white, GU10, 120VAC/240VAC, 30 degree, Edison LED	pcs

Technical Specifications

Physical Specifications

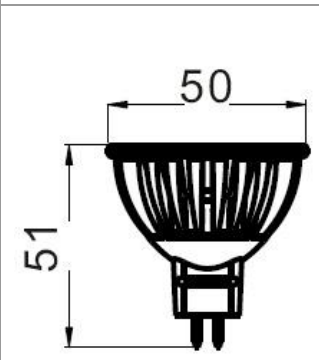
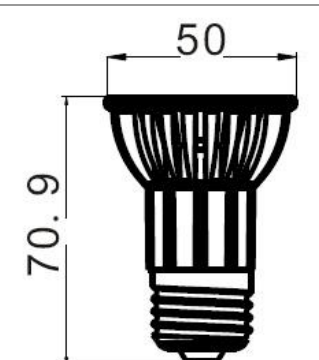
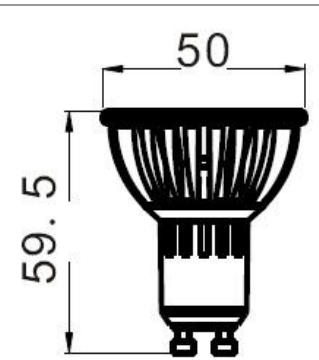
Base	MR16	E27	GU10
Dimension	L51*H50 mm	L70.9*H50 mm	L59.5*H50 mm
Drawing			
Housing	Aluminum		
Work Environment	Indoor use, applicable for dry environment		

Electrical Specifications

Lighting Source	High Power LEDs
LED Quantity	3LEDs x 1W
Operation Voltage	100~240VAC or 12VDC/VAC
Operation Current	350 mA
Power Consumption	3W
Operation Temperature	-20°C~50°C (-4°F~122°F)

Optical Specifications

Color Range	Warm White, Natural White
Lumens	165 lm
Beam Angle	30 Degree
Lumen Maintenance	>995% @ 1000hrs
Color Temperature	3000K~6000K

Comparison between Leds Online Canada eLucent™ GX1019 XPower LED Lamp with Halogen Lamp

	LED Lamp	Halogen Lamp
Power Consumption	Low	High
Life Span	>50,000 hours	3,000~5,000 hours
Directed Light	Yes	No
Heat Generation	Low	High
Radiation	No	UV, FR or mercury
Resistant to shock and vibration	High	Low
Maintenance Fees	No	High
Environmental Pollution	No	High

All these products are available at www.LedsOnline.ca

Products using Voltages higher than 42.8V not certified UL or CSA cannot be sold to Canada.

Contacts:

Sales: sales@LedsOnline.ca

Informations: info@LedsOnline.ca

Support: support@LedsOnline.ca

